

Tiffany Q. Liu  
April 27, 2011  
CSC 270  
Lab #12

## Lab #12: Adding RAM to Processor

### Introduction

The purpose of this lab is to experiment with adding 1K of RAM (2114) to the 6811 processor. The steps for this lab were first written and then executed.

### Materials



Figure 1. Wiring Kit.



Figure 2. 6811 Microprocessor Kit  
(Taken from D.Thiebaut).



Figure 3. Oscilloscope Cables.



Figure 4. Tektronix Oscilloscope

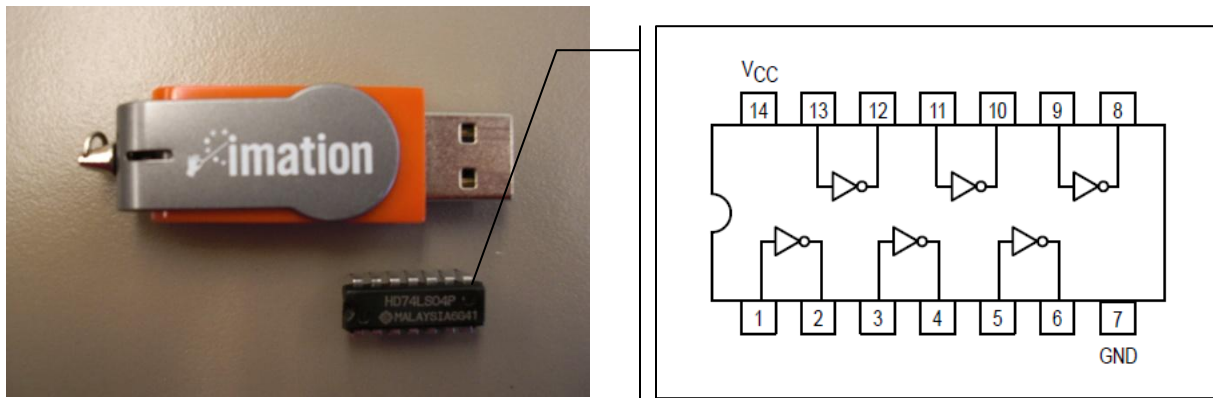

Figure 5. Hex Inverter 74LS04 Compared to a USB Flash Drive.

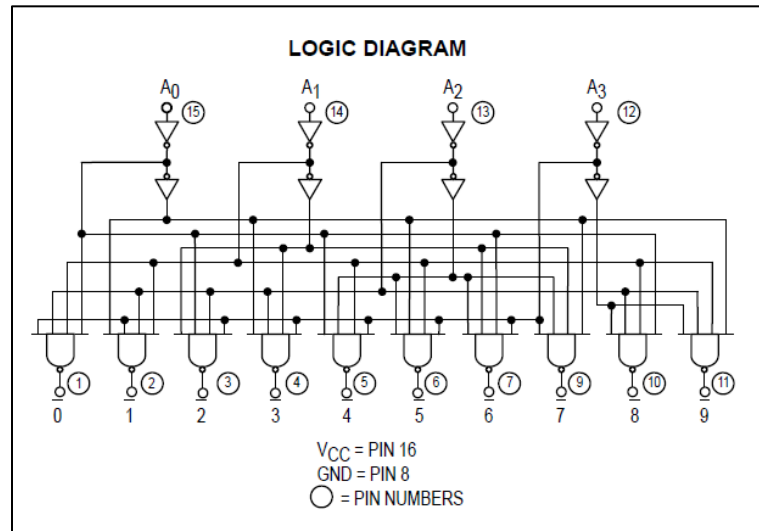
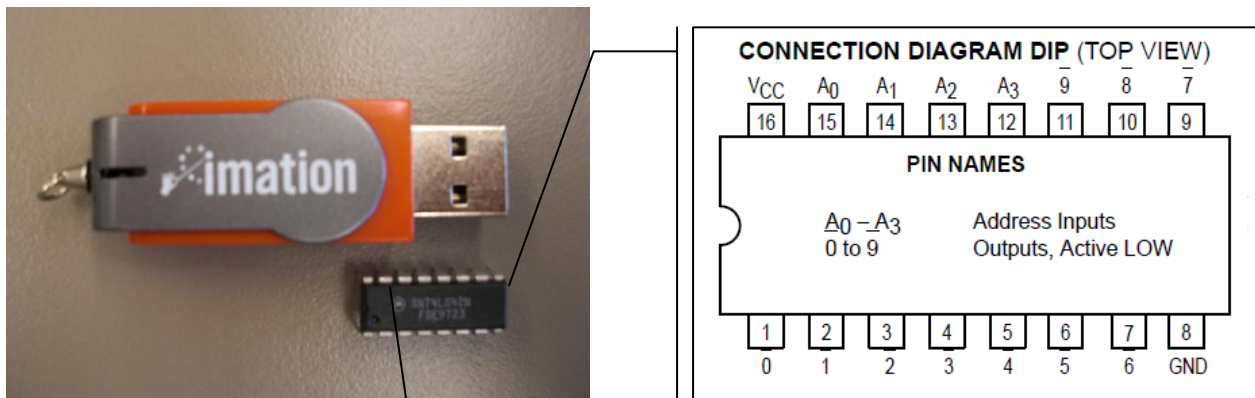

Figure 6. One-of-Ten Decoder 74LS42 Compared to a USB Flash Drive.

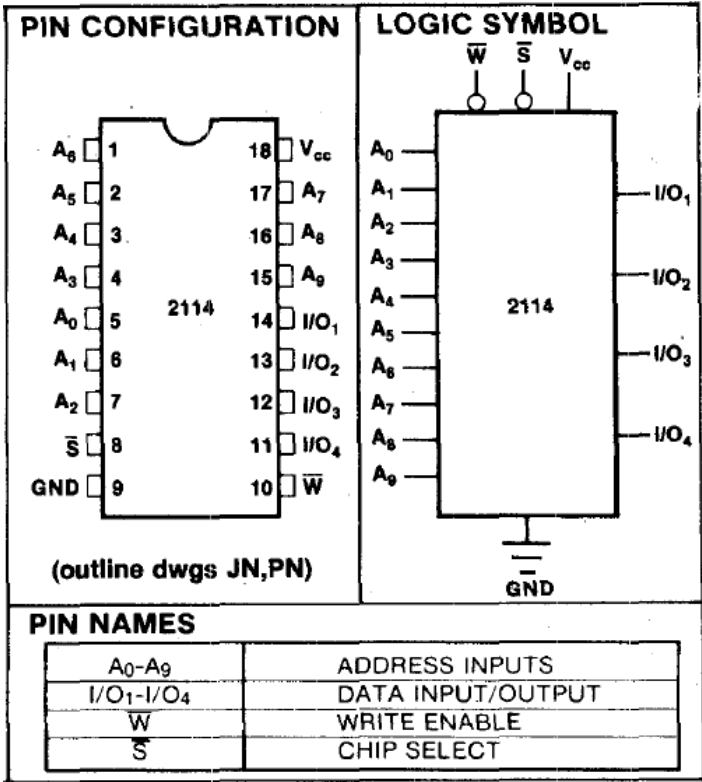

Figure 7. 2114 NMOS Static RAM.

## Circuit Design

To start, a circuit diagram was designed to connect the 6811 to the 2114. The circuit was designed as follows:

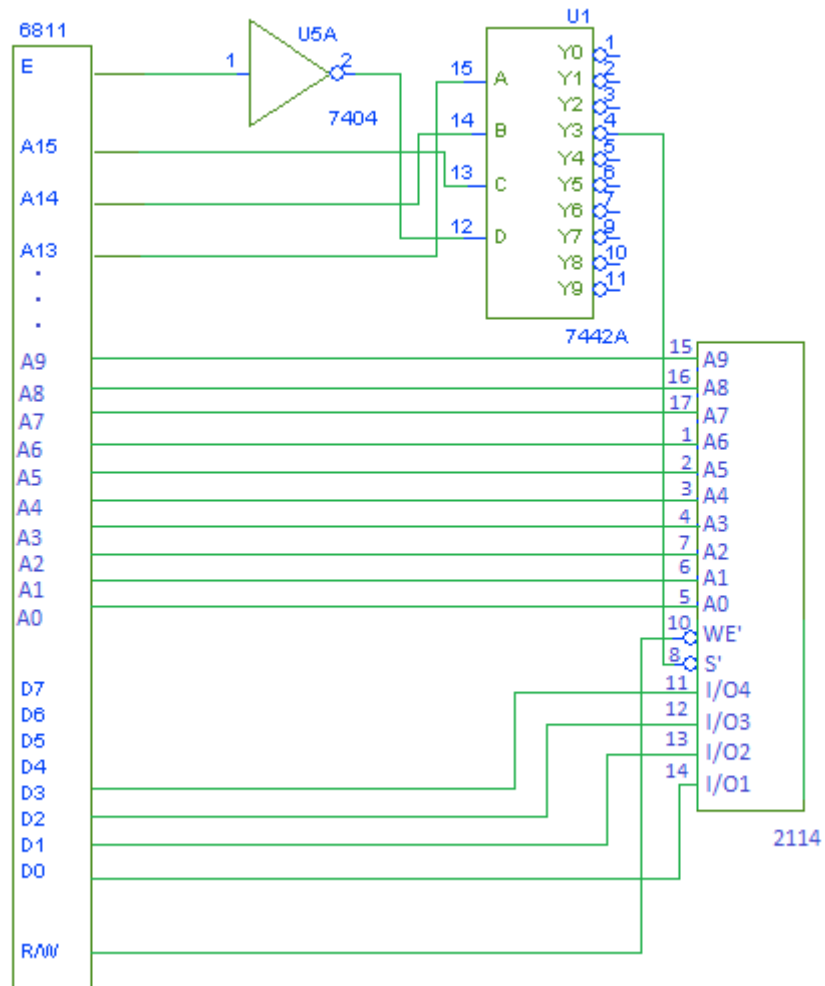

Figure 8. Circuit Diagram for Adding 1K of RAM (2114) to the 6811 Microprocessor.

## Lab Design

Once the circuit diagram was drawn, a series of steps were written out to test to see if our RAM works:

1. Wire the decoder and check that it works by writing and assembling an infinite loop that loads to the I/O port. Enter the program into the 6811 and then put a probe on output y4 to check to see if signal is as expected.
2. Once it has been verified that the decoder was wired correctly, wire the 2114. Do NOT connect the data I/O's on the 2114 just yet! Once everything but the data I/O's on the 2114 have been wired, write and assemble an infinite loop that loads to the I/O port and stores data from the I/O port. Enter the program into the 6811 and take three probes and put them on the output y4 from the decoder, the WE' on the 2114, and the S' on the 2114 to check to see if the signals are as expected.
3. Once the signals have been verified to be correct, we can now connect the data I/O's. Test to see if the RAM works by inserting different values at 8000 and then check to see if the lower four bits have been stored in memory.

### Step 1: Check Decoder

After wiring the decoder following the circuit diagram in Figure 8, the following program was written and assembled:

```

                ;--- data section ---

                ;--- code section ---
                ORG    0000
LOOP:
0000 B6 80 00    LDAA  8000        ; ACCA <-XXXXXXXX
0003 7E 00 00    JMP   LOOP          ; loop infinitely

```

An oscilloscope probe was connected to the decoder y4 output. Once the program was entered into the 6811 and ran, the following screen capture was obtained from the oscilloscope:

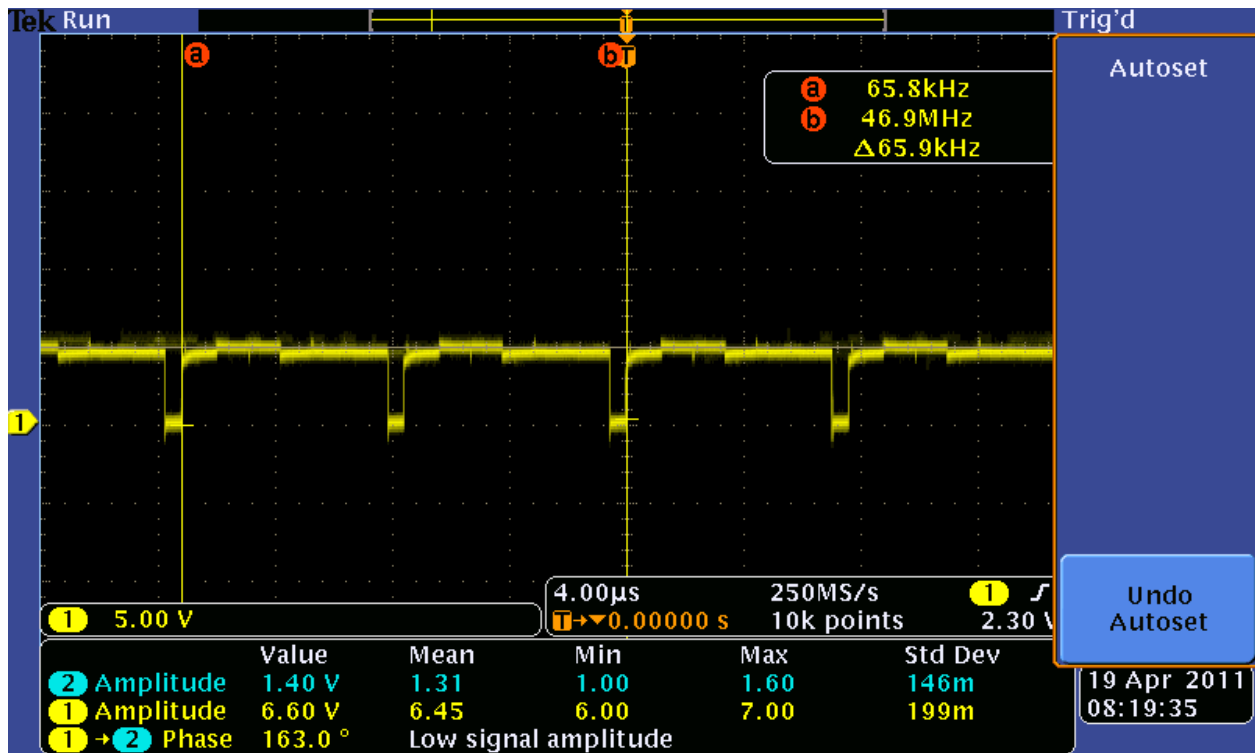

Figure 9. Screen Capture of Decoder y4 Output Signal.

The signal was as expected since an infinite loop that loads to ACCA the value at the I/O port is periodic with one drop in the signal when the value from 8000 gets loaded, thus verifying that the decoder was wired correctly.

### Step 2: Check Non-Data I/O's on 2114

Next we connected the RAM to the 6811 following the wiring diagram in Figure 8. Everything was connected except the data I/O's on the 2114. To check to see if the circuit was wired correctly, the following program was written and assembled:

```

;--- data section ---

;--- code section ---
      ORG    0000
LOOP:
0000 B6 80 00      LDAA  8000      ; ACCA <-XXXXabcd
0003 B7 80 00      STAA  8000      ; RAM <- abcd
0006 7E 00 00      JMP   LOOP      ; loop infinitely

```

Three oscilloscope probes were taken to connect to the decoder y4 output, the WE', and the S' on the 2114. After entering the program and running it, the following screen capture was obtained:

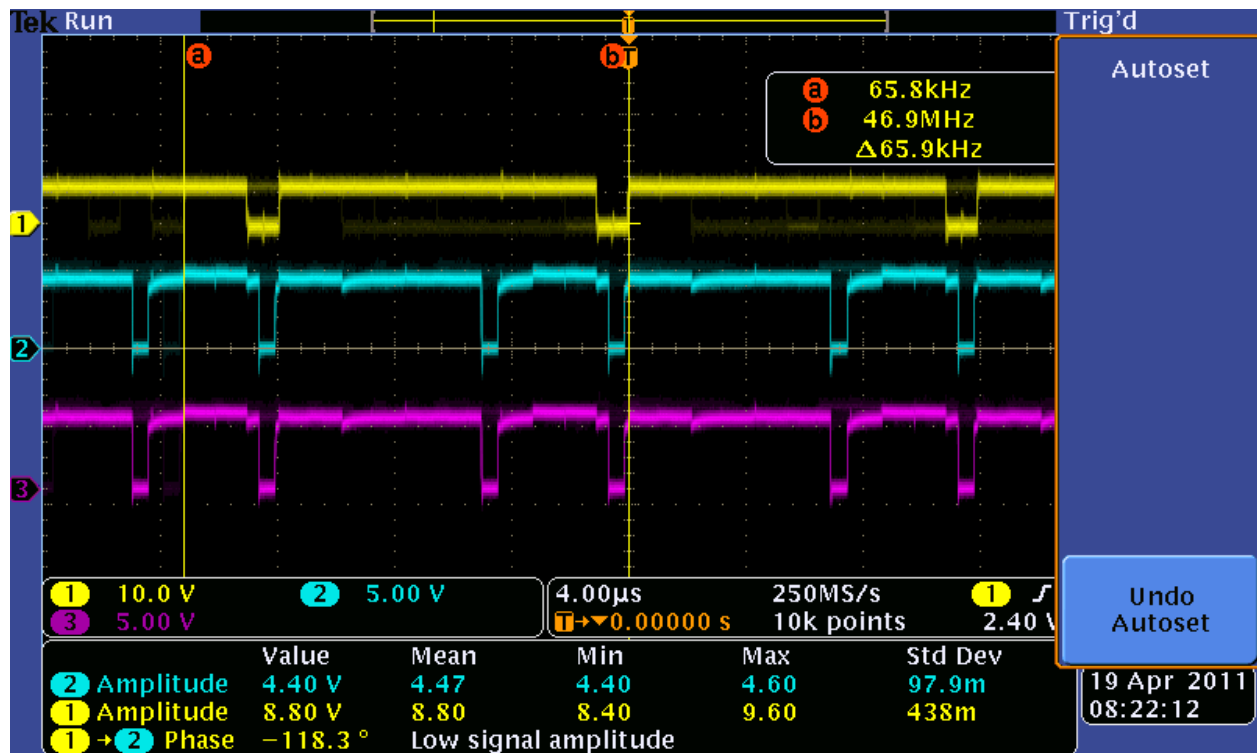

Figure 10. Screen Capture of Decoder y4 Output Signal (Purple), WE' Signal (Yellow), and S' Signal (Blue).

The signal was as expected since the y4 output signal was the same as the S' signal. In addition, the WE' was activated (low signal) only once out of the two low signals in one iteration of the loop, which is expected since the only time the WE' should be activated (low) is when data is being written (STAA). Therefore, it has been verified that the 2114 was wired to the 6811 correctly.

### Step 3: Adding 1K RAM to 6811

Once everything was verified to have been wired correctly, we connected our D0 to D3 pins on the 6811 to the I/O1 to I/O4 pins on the 2114 respectively. To verify that the RAM has been connected to the 6811 starting at memory location 8000, we entered the values 00, 11, 22, 33, 44, ..., FF starting at 8000 by pressing the insert key followed by 8000 on the 6811 keyboard and then entering the values one after the other. Once we finished entering the values, we pressed NMI and then Exm Mem 8000 to examine the memory starting at 8000. The values stored there were F0, F1, F2, F3, F4, ..., FF. This verified that our RAM was connected successfully to our 6811 processor since only the last 4 bits are being stored, which corresponds to the fact that the RAM is only receiving the lower nybble of the data on the 6811 (D0 through D3).