

Tiffany Q. Liu
 January 24, 2011
 CSC 270
 Lab #1

Lab #1: Boolean Algebra and Circuit Wiring with the Digital Training Kit

Introduction

This lab is directed towards students who have been exposed to the Digital Kit before. Thus the focus of this lab is to use AND, OR, and NOT gates with the Digital Kit and show that the gates are designed following the axioms of Boolean Algebra. In addition this lab also exposes us to building a circuit with the logic gates and Digital Kit to implement a function defined by minterms.

Materials



Figure 1. Wiring Kit.



Figure 2. Digital Training Kit.

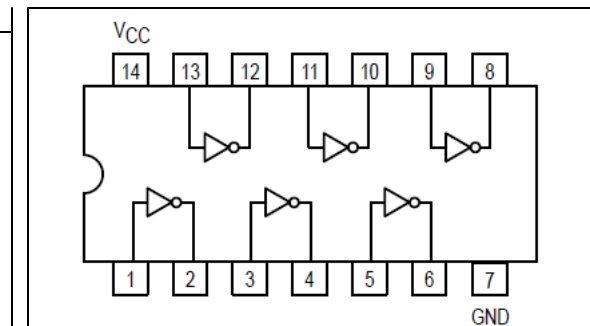

Figure 3. Hex Inverter 74LS04 Compared to a USB Flash Drive.

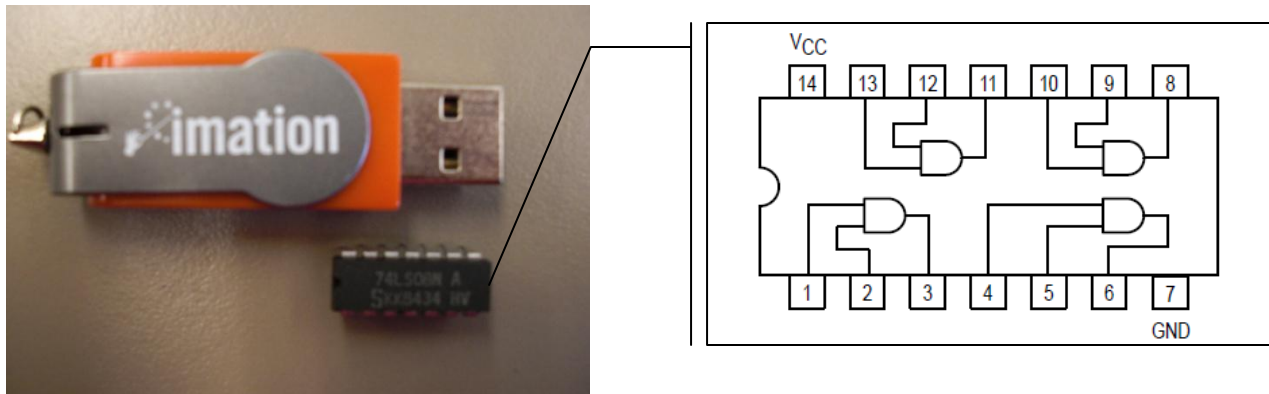

Figure 4. Quad 2-Input AND Gate 74LS08 Compared to a USB Flash Drive.

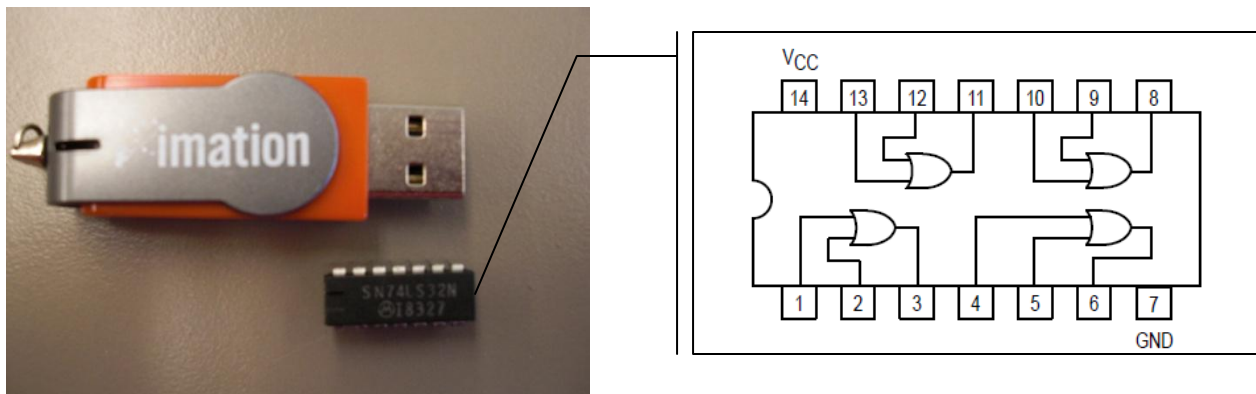

Figure 5. Quad 2-Input OR Gate 74LS32 Compared to a USB Flash Drive.

Boolean Algebra

There are five axioms of Boolean Algebra—associativity, commutativity, absorption, distributivity, and complements. Using the table of Boolean Algebra (Table 1) that illustrates each axiom, a circuit can be designed to test the validity of each axiom.

Associativity	$a \text{ OR } (b \text{ OR } c) = (a \text{ OR } b) \text{ OR } c$	$a \text{ AND } (b \text{ AND } c) = (a \text{ AND } b) \text{ AND } c$
Commutativity	$a \text{ OR } b = b \text{ OR } a$	$a \text{ AND } b = b \text{ AND } a$
Absorption	$a \text{ OR } (a \text{ AND } b) = a$	$a \text{ AND } (a \text{ OR } b) = a$
Distributivity	$a \text{ OR } (b \text{ AND } c) = (a \text{ OR } b) \text{ AND } (a \text{ OR } c)$	$a \text{ AND } (b \text{ OR } c) = (a \text{ AND } b) \text{ OR } (a \text{ AND } c)$
Complements	$a \text{ OR NOT } a = 1$	$a \text{ AND NOT } a = 0$

Table 1. Table of Boolean Algebra Axioms and Their Corresponding Boolean Algebra Expressions.

In order to see if each axiom holds true for the Boolean Algebra expressions given, a circuit can be designed such that the output to the Boolean Algebra expression found on one side of the equation is wired to an LED and the output to the Boolean Algebra expression found on

the other side of the equation is wired to a second LED. The axiom would hold true if and only if for all combinations of values (switch on or switch off) for a, b, and c, either both LED's are on or both LED's are off. In the case of the complements axiom, the axiom would hold true if and only if the light is always on when testing equality to 1 or always off when testing equality to 0.

The following are circuit diagrams used to build circuits on the Digital Kit to test the axioms:

Associativity:

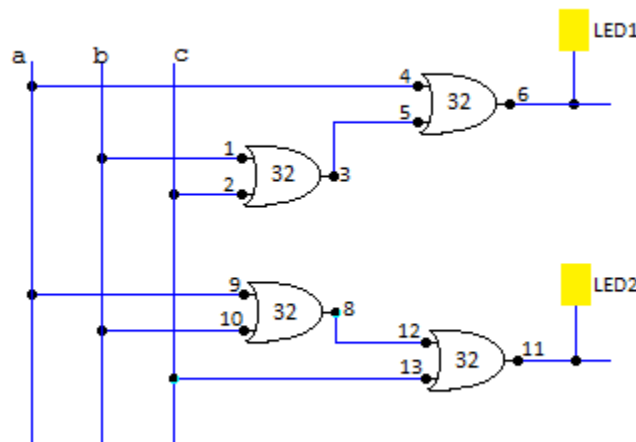

Figure 6. Circuit Diagram to Test $a \text{ OR } (b \text{ OR } c) = (a \text{ OR } b) \text{ OR } c$.

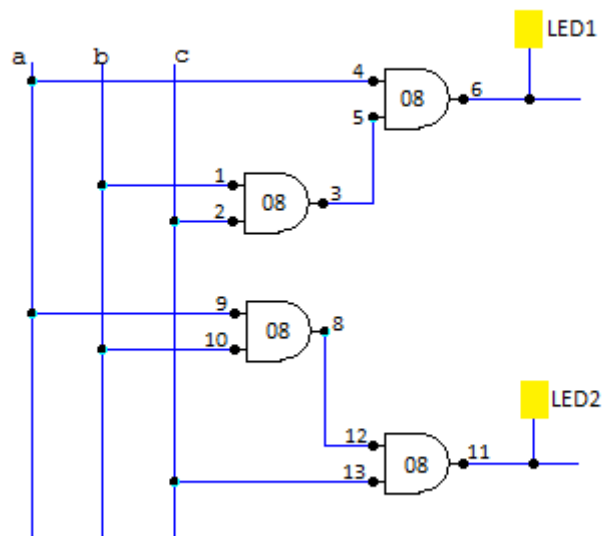

Figure 7. Circuit Diagram to Test $a \text{ AND } (b \text{ AND } c) = (a \text{ AND } b) \text{ AND } c$.

Commutativity:

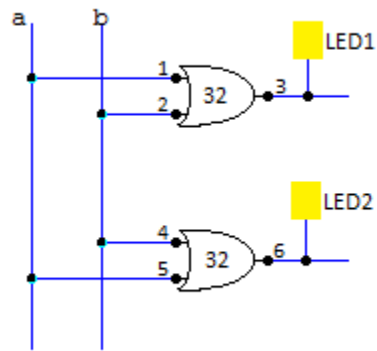

Figure 8. Circuit Diagram to Test $a \text{ OR } b = b \text{ OR } a$.

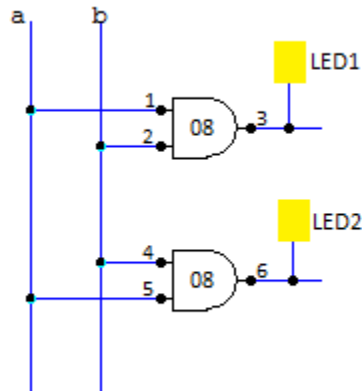

Figure 9. Circuit Diagram for Testing $a \text{ AND } b = b \text{ AND } a$.

Absorption:

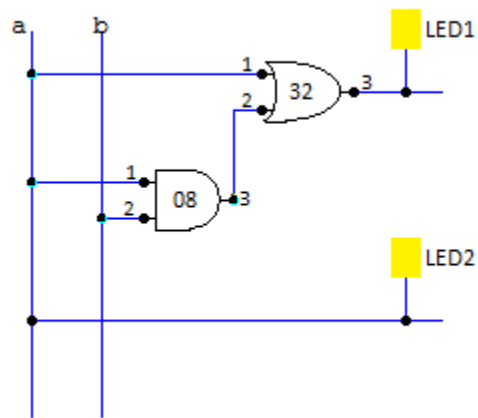

Figure 10. Circuit Diagram for Testing $a \text{ OR } (a \text{ AND } b) = a$.

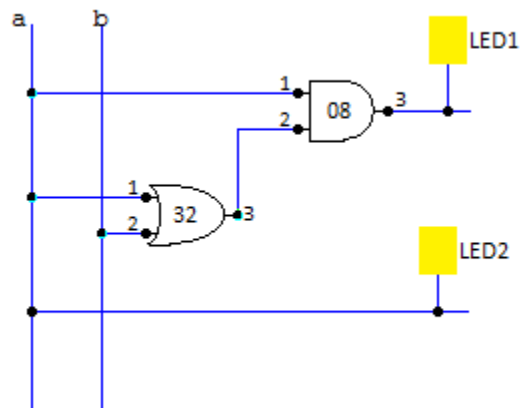

Figure 11. Circuit Diagram for Testing $a \text{ AND } (a \text{ OR } b) = a$.

Distributivity:

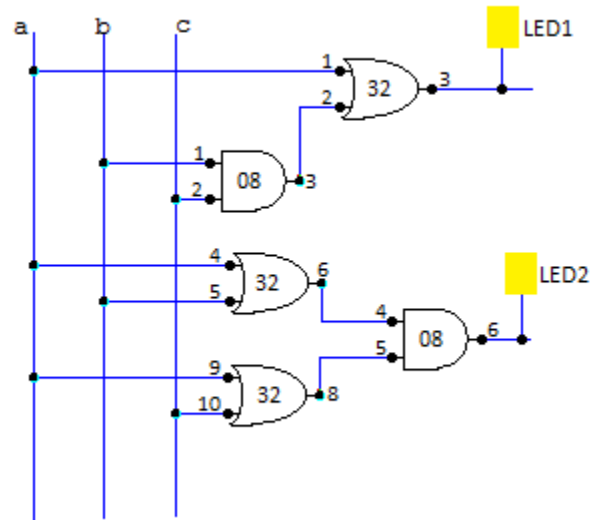

Figure 12. Circuit Diagram for Testing $a \text{ OR } (b \text{ AND } c) = (a \text{ OR } b) \text{ AND } (a \text{ OR } c)$.

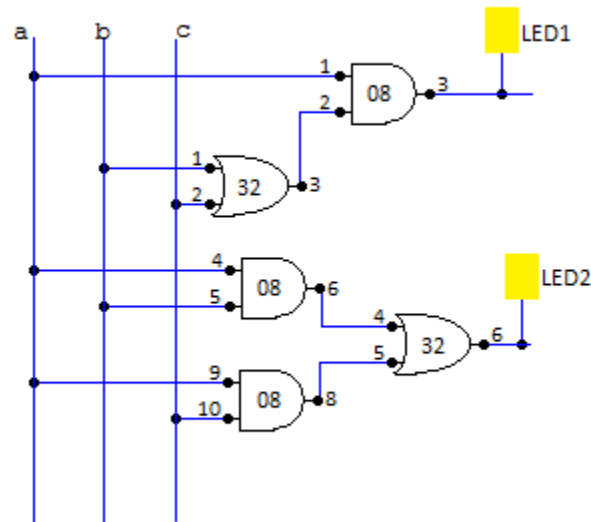

Figure 13. Circuit Diagram for Testing $a \text{ AND } (b \text{ OR } c) = (a \text{ AND } b) \text{ OR } (a \text{ AND } c)$.

Complements:

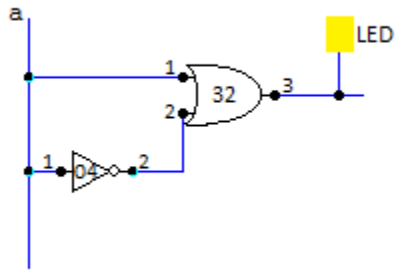

Figure 14. Circuit Diagram for Testing $a \text{ OR } \text{NOT } a = 1$.

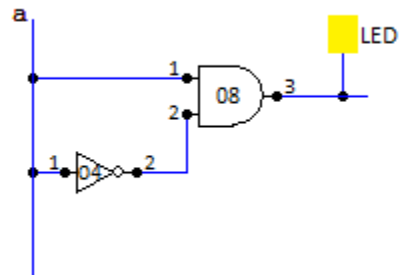

Figure 15. Circuit Diagram for Testing $a \text{ AND } \text{NOT } a = 0$.

Circuit Wiring

For this part, build a circuit using the Digital Kit and the logic gates to implement the function $f(a, b, c) = \Sigma(1, 2, 3, 5, 7)$. To start, a truth table was generated for this circuit and to simplify f as much as possible in order to make the hardware simpler:

a	b	c	f(a, b, c)
0	0	0	0
0	0	1	1
0	1	0	1
0	1	1	1
1	0	0	0
1	0	1	1
1	1	0	0
1	1	1	1

Table 2. Truth Table for the Function $f(a, b, c) = \Sigma(1, 2, 3, 5, 7)$.

Using this table, a simplified expression for f can be derived:

$$\begin{aligned}
 f(a, b, c) &= a' \cdot b' \cdot c + a' \cdot b \cdot c' + a' \cdot b \cdot c + a \cdot b' \cdot c + a \cdot b \cdot c \\
 &= a' \cdot (b' \cdot c + b \cdot c' + b \cdot c) + a \cdot (b' \cdot c + b \cdot c) \\
 &= a' \cdot (b' \cdot c + b \cdot (c' + c)) + a \cdot ((b' + b) \cdot c) \\
 &= a' \cdot (b' \cdot c + b) + a \cdot c \\
 \mathbf{f(a, b, c)} &= \mathbf{a' \cdot (c + b) + a \cdot c}
 \end{aligned}$$

The following circuit diagram was used to wire the Digital Kit based on the simplified version of the function and verified against the truth table for $f(a,b,c)$ (Table 2):

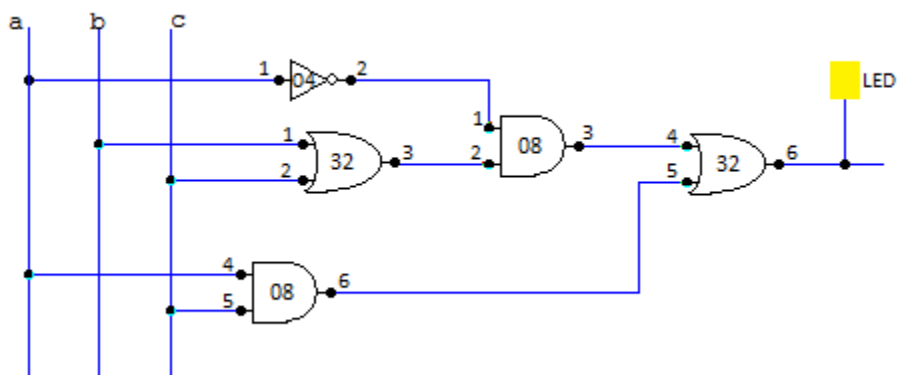

Figure 16. Circuit Diagram for $f(a, b, c) = \Sigma(1, 2, 3, 5, 7)$.